

40 - 125 kVA



EFFICIENCY HAS A NEW NAME. **KOEL GREEN.**

**EFFICIENT
PRODUCTS**



**EFFICIENT
SERVICE**



**EFFICIENT
DELIVERIES**



**EFFICIENT
SOLUTIONS**

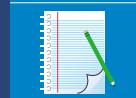

**EFFICIENT
NETWORK**



**EFFICIENT
24X7 CARE**



- INDIA'S **#1** GENSET BRAND
- 15 - 5200 kVA

**KOEL
GREEN**
BY
KIRLOSKAR
EFFICIENCY. INTEGRATED

40 - 125 kVA

Prime Rating at rated rpm (as per ISO8528) ¹		kVA	40	40	45	62.5	62.5	82.5	100	125	125HD	
		kW	32	32	36	50	50	66	80	100	100	
Genset Model			KG1-40AS	KG1- 40WS	KG1 - 45WS	KG1-62.5AS	KG1- 62.5WS	KG1- 82.5WS	KG1-100WS	KG1-125WS	KG1-125WS HD	
Frequency		Hz	50	50	50	50	50	0.8	0.8	0.8	0.8	
Power factor		lagging	0.8	0.8	0.8	0.8	0.8					
Voltage		V	230 (1Ø) & 415 (3Ø)					415 3Ø				
Governing class (As per ISO 8528 Part-V)			G2	G2	G2	G2	G2	G2	G3	G3	G3	
Noise level		dB(A)	< 75	< 75	< 75	< 75	< 75	< 75	< 75	< 75	< 75	
Fuel Consumption*		At 100 % Load	9.9	9.2	10.3	16.2	14.1	18.8	21.9	27.4	27.5	
		At 75 % Load	7.9	7.4	8.7	12.7	11.3	13.8	16.9	20.2	21.4	
		At 50 % Load	5.8	5.5	5.9	8.9	7.5	9.9	12.2	15.3	15.3	
Fuel tank capacity		Ltrs	100	100	100	150	150	150	230	230	230	
Weight of genset with canopy (approx.) ^o		Dry	Kg	1270	1250	1250	1700	1420	1710	2040	2090	2520
		Wet	Kg	1370	1335	1335	1825	1550	1840	2240	2290	2730
Overall dimensions of genset ^o		Length	mm	2400	2550	2550	3150	2800	3200	3200	3200	3650
		Width	mm	1050	1050	1050	1200	1100	1100	1300	1300	1350
		Height	mm	1670	1450	1450	1635	1595	1595	1795	1795	1915
Electrical Battery starting voltage		Volts-DC	12	12	12	12	12	12	12	12	12	
ENGINE												
Engine Model			HA494TCI G1	3R1040TA G1	3R1040TA G1	HA694TCI G1	4R810TA G1	4R1040TA G1	4K1080TA G2	4K1080TA G2	6R1080TA G1	
Rated output (Prime Continuous rating as per ISO 8528-1)		kW	41.19	41.2	41.2	61	61	74.8	114.7	114.7	114.7	
		HP	56	56	56	83	83	102	156	156	175	
No. of cylinder		Number	4	3	3	6	4	4	4	4	6	
Cubic capacity ²		Ltrs	3.77	3.12	3.12	5.65	3.24	4.16	4.32	4.32	6.49	
Bore x Stroke		mm	100 x 120	105 x 120	105 x 120	100 x 120	96 x 112	105 x 120	105 x 125	105 x 125	105 x 125	
Rated Speed		RPM	1500	1500	1500	1500	1500	1500	1500	1500	1500	
Aspiration		NA/TC/TA	TC	TA	TA	TC	TA	TA	TA	TA	TA	
Lube Oil change period		hrs.	500	500	500	500	500	500	500	500	500	
Lube oil Sump Capacity		Ltrs	8.3	8	8	11	10	10	18	18	18	
Coolant Capacity		Ltrs		11.5	11.5		17.5	24	21	21	28	
ALTERNATOR												
Insulation Class			Class H									
Alternator Efficiency (at 100% load) 0.8 pf**		%	89.2	89.2	89.2	91	91	91.4	92	92.5	92.5	
Max Voltage Dip at Full Load 0.8 pf Lag		sec	≤ 16 %	≤ 16 %	≤ 16 %	≤ 20 %	≤ 20 %	≤ 20 %	≤ 20 %	≤ 20 %	≤ 20 %	
Max Time to build up rated voltage at Rated RPM			< 5 sec provided engine reach the rated speed					Voltage recovery time 6 sec				

For intermediate ratings, kindly contact nearest KOEL office

Notes

¹ Tolerances Apply

*With 0.845 Specific Gravity of diesel (5 % Tolerance)

^o These weight are for handling & transportation only

** Efficiency of Alternator as per standards IS 4722 and IEC 34-1

For Site Conditions other than standard operating conditions consult KOEL for available prime power.

Prime rating and Stand-by rating ¹



'Prime power' is designed for Unlimited hours, as compared to 'Emergency stand-by' designed for 200 hours in a year. Prime rated Gensets also permit 10% temporary overloading. Users need to carefully select the Genset rating to meet their requirement. KOEL offers Prime power as a standard offer. Contact KOEL for stand-by ratings.

Engine capacity does matter ²



Engine capacity (cc) plays a vital role in Genset performance. Higher engine capacity leads to a robust and stable Genset performance.

Higher engine capacity also enables the Genset to respond quickly & positively to sudden load additions.

Canopy

- Ease of Access and Serviceability
- Aesthetically designed, weather and sound resistant enclosure
- Insulation conforms to UL94-HF1 class for flammability

Controller

- Microprocessor based
- Graphical LCD display
- Best in class monitoring and diagnostic Capability
- Integrable with AMF, synchronization & communication configurations

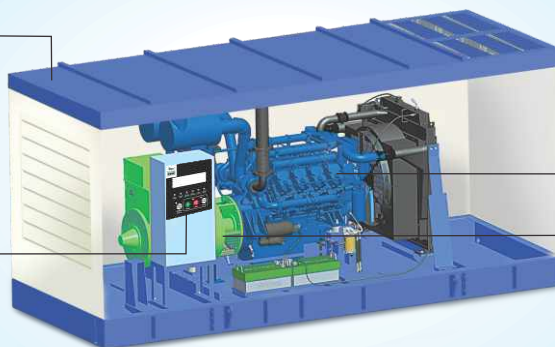

Engine

- O2E Series: Low emission, high efficiency engines
- Compact, Robust and Rugged Design
- 500 hours lube-oil change period

Alternator

- Best In Class Efficiency
- Special Windings to Reduce Harmonics
- Vacuum Pressure Impregnation and epoxy gel coating on the winding

KOEL's approach to meet revised CPCB norms

Revised CPCB norms are aimed at protecting the environment by reducing Genset emissions and improving emission quality. These are some of the most stringent emission norms in the world.

To meet the new norms, KOEL R&D team had choice of multiple technologies. While selecting the technology, KOEL laid significant emphasis on long term needs of users viz:

- High reliability and durability of Gensets: Owing to extreme operating conditions in India, preference has been given to robust configurations that have been running successfully for several years.
- Low running costs: An effort to reduce emissions tends to increase the running costs. KOEL has succeeded in achieving both in the same design.

- Optimized fuel efficiency as per actual usage: KOEL Green Gensets are tuned to provide maximum fuel efficiency in the most common operating band. At KOEL, we call it **O2E series** (Optimal Operating Efficiency).
- Affordable, On-site support: Proven technology ensures that product support is available close-by, without waiting for a specialist. KOEL team has taken special efforts to keep complex technologies at bay, which may require high on-site maintenance costs.

All this, while keeping the initial costs within the reach of a smart Genset buyer.

Integrated



Best-in-class Fuel Efficiency

Koel Green Gensets offer a unique combination of CPCB norm compliance and enhanced fuel efficiency. Across the range, KOEL Green Gensets offer substantial savings in fuel cost.

O2E Series (Optimal Operating Efficiency):

Genset ratings are selected based on the present load and future expansion. Fuel efficiency of most Gensets is optimized at the full rating of the Genset.

In practice, Gensets rarely get loaded to full capacity. Power demand variations across day & night, weekdays & weekends.

Summer & winter lead to an average 50-70% loading on the Gensets.

Considering this practical situation, KOEL has extended fuel efficiency optimization from 100%, right up to 50% of rated load.

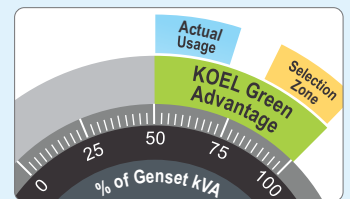

Combination of best-in-class fuel efficiency & O2E provides a double advantage.

Integrated



Genset Controls at your finger-tips

There is no comfort like being in command. KOEL Green Gensets put the command in your hands. Micro-processor based Genset controllers display a host of Genset parameters and put all controls at your fingertips.

Monitoring Features –

- Phase Voltages, Phase Currents, kVA, kW, kWh, kVAr, Power Factor
- Lube oil Pressure, Engine Temperature, RPM, Run Hours, Number of starts, Fuel Level, Auto / Manual Stop
- Battery charge condition
- Common Alarm / Hooter output, AMF feature with ATS

Diagnostic Features –

- Battery charging failure, Over/Under speed, Over Current, Over/Under Voltage, Over kW, Phase Sequencing, Phase missing
- Low Lube oil Pressure, High Engine Temperature, Low/High battery voltage, Low Fuel Level, Over Crank protection, Routine Maintenance indicator, Genset Test Facility

KG934 Controller

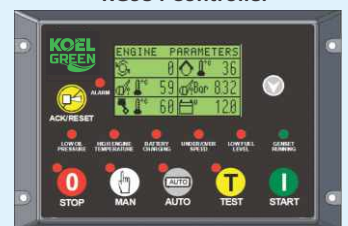

Optional Features-

- Modbus communication

Integrated



Peace-of-mind Ownership

KOEL Green Gensets have always been preferred for their robust design and reliability over long usage life.

KOEL Green range carries the confidence of well-established and proven engine platforms. For compliance to revised CPCB

norms, KOEL has carefully selected those technologies which not only retain, but enhance Gensets durability and on-site serviceability.

Thus, KOEL Gensets offer you many years of trouble-free performance; backed by the assurance of prompt support. Peace-of-mind driven by product reliability and low cost of ownership.

The Promise Behind The Product



KOEL Green Brand

KOEL Green is the Genset brand of Kirloskar Oil Engines Ltd (KOEL), the flagship company of the century-old Kirloskar Group. KOEL Green is India's largest selling and most trusted Genset brand for over a decade. Providing back-up power solutions from 15 to 5200 kVA for diverse market sectors, "KOEL Green" has over 1 million Gensets in service across the globe.

Research and Engineering

KOEL Gensets are designed and developed indigenously, using modern design & simulation technologies. KOEL's R&D team combines decades of application knowledge, global technology trends and emerging user expectations to develop best-in-class products for the target markets. The products are launched after extensive validation in world-class facilities.



State-of-the-art Manufacturing

KOEL Green Gensets are manufactured at the state-of-the-art manufacturing facilities of KOEL and authorized GOEMs across India. Common design, modern infrastructure, trained manpower, stringent process controls and standardized material quality ensure that every KOEL Green Genset complies with the standards and meets KOEL's stringent quality norms.

Sales Network

A well-trained network of authorized KG Dealers and GOEM Sales teams is spread across India to serve your requirements. KOEL offices at key locations provide further techno-commercial back-up. KOEL Sales teams are equipped to carry-out load study, Genset sizing and techno-commercial support. Installation and commissioning activities are also undertaken in line with KOEL's stringent guidelines.



Service Network

As Genset cannot be driven to a Service Station, service has to come to your door-step. KOEL Green Gensets are supported by over 5000 trained Engineers and over 450 well-equipped service outlets throughout India. Standard and custom-made maintenance packages offer a total-peace-of-mind ownership experience. Service response time and quality is centrally monitored for cross-industry benchmarking and continual improvement. Customers just need to dial our toll free number and service will be available at the door step.

7 Easy steps for a happy Genset Ownership

- Insist on a load-study
- Select the Genset rating as per the load-study and with sufficient margin for future load expansion
- Apply site-selection guidelines carefully
- Insist on installation in line with KG guidelines
- Ensure adequate size and proper connection of cables
- Understand the Genset operation & maintenance procedures during commissioning
- Follow routine maintenance protocols through authorized KG service dealers

Product improvement is a continuous process. Kindly contact KOEL for latest information

- Ahmedabad: 079-2692 9687/89 ● Bengaluru: 080-490 31130 ● Bhubaneshwar: 0674-258 8047 ● Chennai: 044-237 44624 ● Delhi: 011-2871 5826
- Guwahati: 0361-245 7616 ● Indore: 0731-3913100 ● Jaipur: 0141-2370007 ● Kochi: 0484-238 5757 ● Kolkata: 033-217 0858 ● Lucknow: 0522-274 1442
- Ludhiana: 0161-254 6668/69 ● Meerut: 0121-240 1199 ● Mumbai: 022-6151 1234 ● Patna: 0612-222 0412 ● Pune: 020-2581 0341
- Secunderabad: 040-275 34176/97

KIRLOSKAR OIL ENGINES LIMITED

Laxmanrao Kirloskar Road, Khadki,
Pune 411 003 INDIA.
www.koelgreen.com

 **8806334433**
1800 233 3344
koel.helpdesk@kirloskar.com

Stamp of
Authorised
Representative